

MODEL No.:

# 1812-XXSF

NOTE: Information herein is believed by Southwest Microwave, Inc. to be accurate. However, Southwest Microwave assumes no responsibility for any omissions or errors or inaccuracies for its use or for any infringements of patents or other rights of third parties that may result from its use. Data is intended for informational purpose only and does not constitute a contract of sale or any express or implied warranty, including any warranty of merchant ability or fitness for a particular purpose.

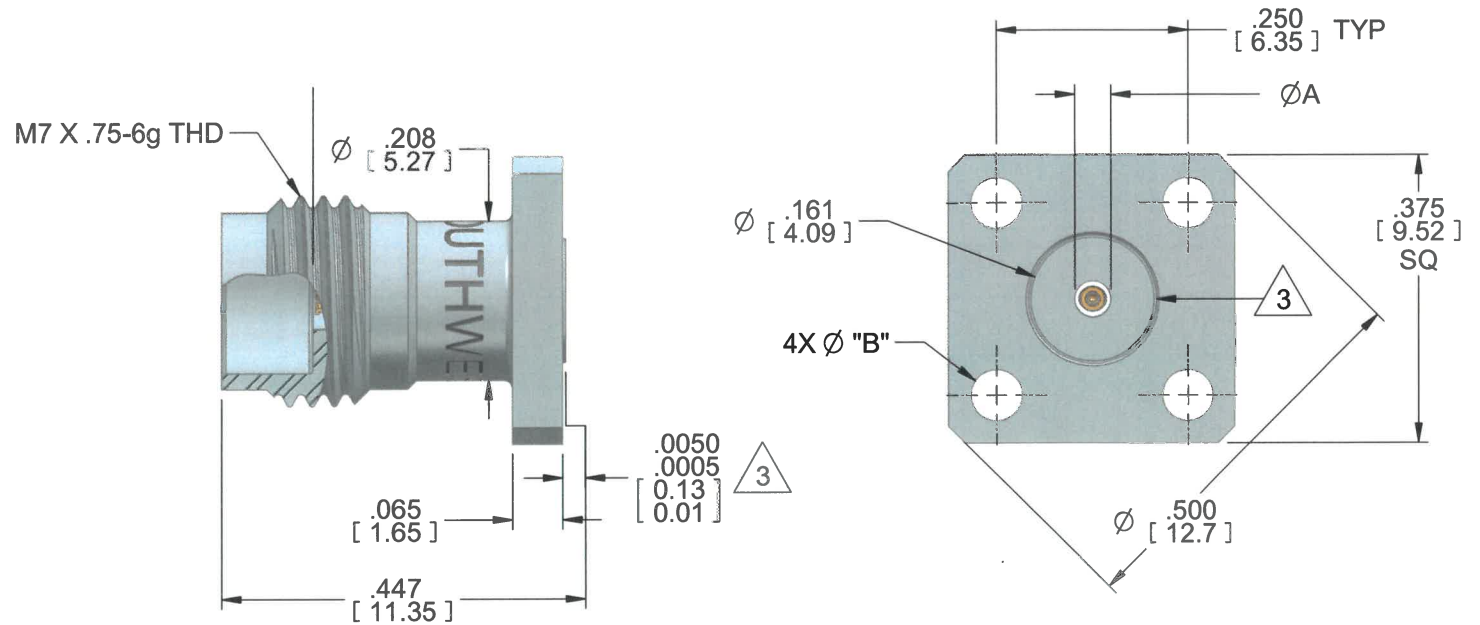

HOUSING:	STEEL, CRES ALLOY UNS 30300 PER ASTM A582 PASSIVATED PER ASTM A967-99
CONTACT:	BeCu UNS C17300 PER ASTM B196 GOLD PLATE PER MIL-DTL-45204
BEAD:	VIRGIN PTFE FLUOROCARBON PER ASTM D1710, TYPE 1 GRADE 1, CLASS B
CAPTURE BEAD:	ULTEM 1000 PER ASTM D5205
ITEM	MATERIAL & FINISH

Model	Pin Size	Max. Pin Depth	Ø A	Ø B
1812-02SF	.009	.065	.047	.067
1812-05SF	.012	.065	.056	.067
1812-09SF	.009	.065	.047	.081
1812-10SF	.012	.065	.056	.081

3. 360° RAISED METAL GROUNDING RING.

2. SEE DOCUMENT NO. 91R60815 FOR PRODUCT SPECIFICATIONS.

1. ALL DIMENSIONS ARE IN INCHES. ALL ANGLES ARE IN DEGREES. DIMENSIONS SHOWN IN BRACKETS [XXX] ARE IN MILLIMETERS.

NOTES: UNLESS OTHERWISE SPECIFIED.

REV B	ECN 9728	REV BY. JAC	APRVD. JW	DATE: 03/13/18
-------	----------	-------------	-----------	----------------



Southwest Microwave, Inc.  
9055 South McKemy Street  
Tempe, Arizona 85284-2946  
Telephone (480) 783-0201  
Fax (480) 783-0360

TITLE  
**1.85mm Jack (Female)  
.375" Square Flange**

DRN BY: EAG	DATE: 4/30/12	DWG. NO. 91R60816	REV. B
SHEET: 1 OF 1			