

Key Features

- Amplitude Leveling
- Low Phase Noise
- Exceptional Isolation
- Conveniently Daisy-Chained
- Miniature/Embeddable
- Broad Input Power Range

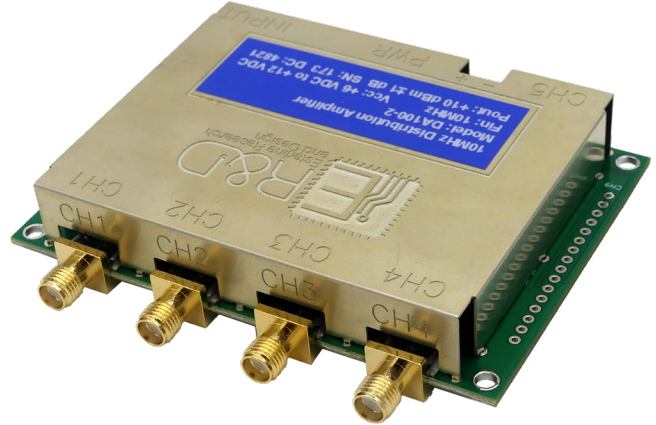

Applications

- Frequency Standard Distribution
- Test and Instrumentation

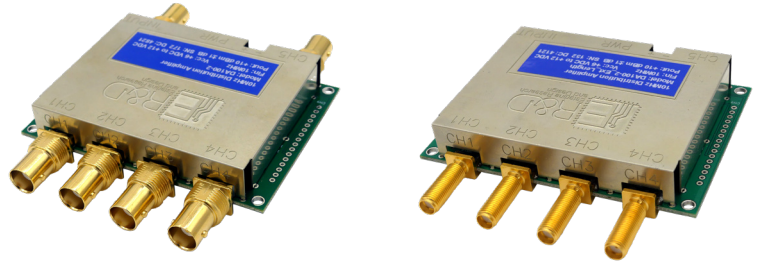

Functional Description

The primary function of our DA100 distribution amplifier is to distribute an existing signal to multiple points while preserving its integrity. The DA100 is ideal for situations requiring a low noise RF signal to be supplied to multiple usage points.

The DA100 has one input channel and five output channels. It may be configured with either SMA or BNC connectors (details provided in the connector table on page 4). The input is AC-coupled and has a 50 Ω source impedance. It includes a limiter circuit that not only provides a fixed output level but also offers high input gain. This design allows the amplifier to maintain the specified output power across a wide range of input power levels.

The input limiter is followed by three amplifier/low-pass filter stages, which insure low-distortion sine wave outputs. The outputs from the filter stages are supplied to fixed-gain output amplifiers. This configuration achieves channel to channel phase offset of under 1 ns; the phase offset from the input to any output is less than 5 ns at 10 MHz.

For larger systems requiring more outputs, multiple amplifiers may be daisy-chained together by connecting the output of channel five to the input of another distribution amplifier. However, this configuration increases phase offset between amplifiers. If channel-to-channel phase offset is a concern, the recommended configuration would be to use a single amplifier to drive up to five additional amplifiers. This will provide up to 25 outputs with minimal channel-to-channel phase offset.

Standard Specifications:

Parameter	Minimum	Typical	Maximum	Units
Input¹				
Frequency Range ²	1.0		100	MHz
Amplitude	-10		+16	dBm
	0.2		4.0	V _{pp}
Impedance	45		55	Ω
Output				
5MHz THD ³	N/A	0.7	1	%
10MHz THD ³	N/A	0.6	1	%
100MHz THD ³	N/A	3.5	-	%
5MHz Amplitude (50Ω Load) ²	+8.0	+10	+12	dBm
10MHz Amplitude (50Ω Load) ²	+8.0	+10	+12	dBm
100MHz Amplitude (50Ω Load) ²	+5	+6	+7	dBm
10MHz Amplitude (High Z Load) ⁴	1.00		1.30	V _{rms}
Channel-to-channel Isolation	70		N/A	dB
Power Requirements⁵				
Voltage	6		12	VDC
Current ⁶	N/A		250	mA

Notes:

1. Input signal waveform can be any type with a 50% duty cycle.
2. Amplifiers are purchased at a fixed frequency. Can accommodate any frequency between 1-100 MHz, with a minimum bandwidth of ± 5%.
3. As calculated using fundamental power level and 2nd and 3rd harmonic power level.
4. Min and max output characteristics specified is using a 10 MHz input.
5. The device may be powered with a user-supplied voltage via the screw terminal connections or a 2.1 mm plug on a 6 V, 500 mA power module (a suitable module can be supplied upon request). When the power module is utilized, the module voltage is made available on the screw terminals, allowing the user to access 6 V, 250 mA to power external circuitry.
6. Max current specified is using a 10 MHz input.

Caution: Do not connect an external supply voltage to the screw terminals when using the power module.



Mechanical Specifications:

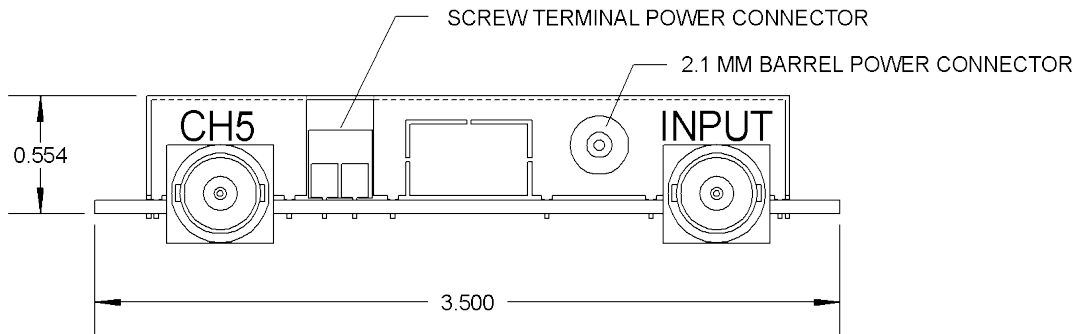
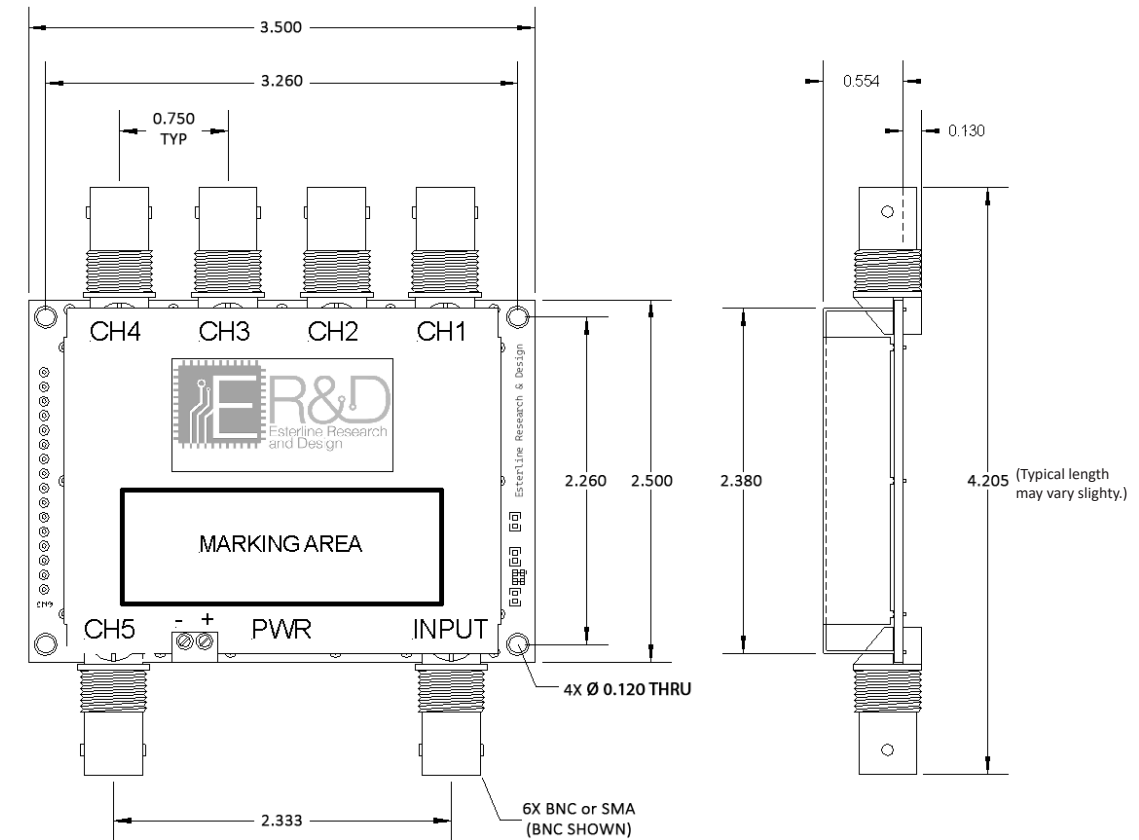

All dimensions are in inches with a tolerance of $\pm 0.020''$ Unless otherwise specified.

Ordering Information:

DA100-10M00-A

Frequency specified in Hz with M as the decimal. 10MHz in the example.

5MHz, 10MHz, and 100MHz standard frequencies. Alternate frequencies are available upon request.

Connector Configuration

DASH #	Configuration
A	BNC
B	SMA1
C	SMA2
D	SMA3
E	SMA4

Connector Configurations

Part Number Code	Configuration
BNC	BNC on both sides
SMA1	Short SMAs on both sides
SMA2	Panel-mount SMAs on front, short SMAs on rear
SMA3	Panel-mount SMAs on rear, short SMAs on front
SMA4	Panel mount SMAs on both sides